

# Specifications



MEASUREMENTS	Metric	US
Working height, max.	30,00 m	97 ft 10 in
Horizontal outreach with 80 kg	15,70 m	51 ft 6 in
Horizontal outreach with 200 kg	14,00 m	45 ft 11 in
Up and Over Clearance, max.	-	-
Platform height (A)	1,10 m	3 ft 7 in
Platform length (B)	0,80 m	2 ft 8 in
Platform width (C)	1,20 m	3 ft 11 in
Length, overall (D)	7,20 m	23 ft 8 in
Height, travel position (E)	1,98 m	6 ft 6 in
Width, minimal overall width (F)	1,58 m	5 ft 3 in
Max. ground clearance (G)	1,26 m	4 ft 1+ in
Track (L x W) (H)	1,92 m x 0,25 m	6 ft 2 in x 10 in
Length outrigger footprint standard (I)	5,30 m	17 ft 5 in
Width outrigger footprint standard (J)	4,75 m	15 ft 7 in
Length footprint one side narrow (K)	6,64 m	21 ft 9 in
Width footprint one side narrow (L)	3,95 m	12 ft 11 in
Width footprint both sides narrow (M)	2,99 m	9 ft 10 in
Outrigger plate Ø	0,31 m x 0,22 m	12 in x 8 ½ in

PRODUCTIVITY	Metric	US
Basket capacity	200 kg	441 lbs
Movable Jib	180°	180°
Basket rotation	180°	180°
Turret rotation	450°	450°
To be jacked up on ground slope of	16,7°/30 %	16.7°/30 %
Height and width track adjustment	22/17 cm	8 ¾/6 ¾ in
Gradeability max.	16,7°/30 %	16.7°/30 %
Slope angle	16,7°/30 %	16.7°/30 %
Travel speed	3,0 km/h	1.9 mph

WEIGHT	Metric	US
Total weight	4225 kg	9,380 lbs
Live load in travelling position	3,7 kN/m <sup>2</sup>	75.0 psf
Live load in working position	2,0 kN/m <sup>2</sup>	41.8 psf
Max. point load per outrigger plate	26,0 kN	5845 lbf

POWER		
Standard power sources (Electric & combustion engine)	<b>1) Diesel:</b> Kubota D 902-E (16.1 kW, 21.9 hp) <b>2) Electric motor:</b> 115 V (US), 230 V (EU)	
Optional power sources	<b>1) Battery:</b> 80 V Battery drive	
Fuel tank capacity Diesel engine	40,0 l	10.5 gal

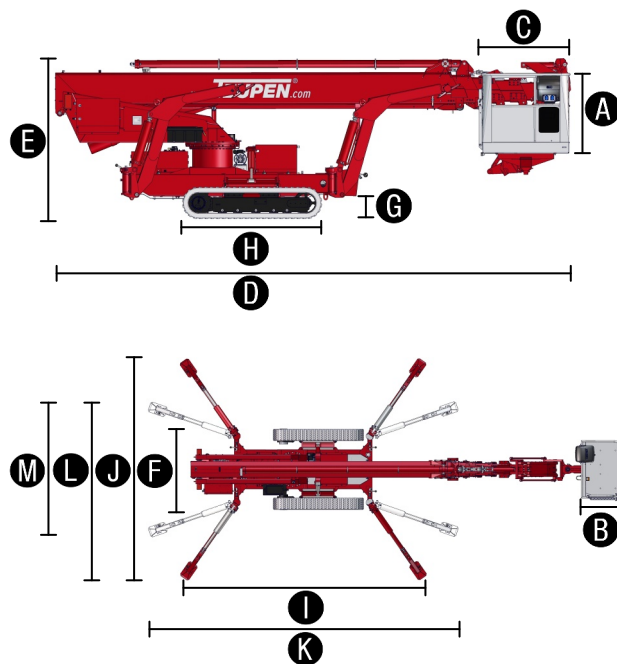

## WORKING ENVELOPE

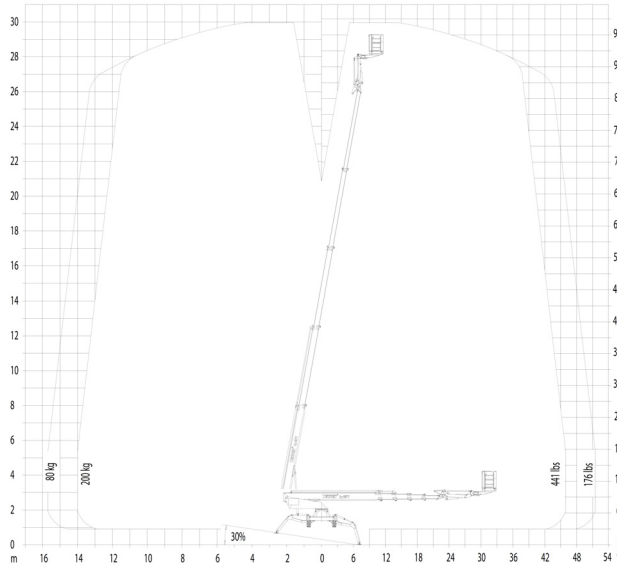

## STANDARDS COMPLIANCE



EN ISO 9001



ANSI A92.5-2006  
CSA B354.1-04  
EN 280:2001

Product specifications are subject to change without notice or obligation. Photographs and drawings in this document are for illustrative purposes only. Refer to the appropriate Operator's Manual for instructions on the proper use of this equipment. Failure to follow the appropriate Operator's Manual when using our equipment or to otherwise act irresponsibly may result in serious injury or death. The only warranty applicable to our equipment is the standard written warranty applicable to the particular product and sale and we make no other warranty, expressed or implied. Products and services listed may be trademarks, service marks or trade-names of Teupen Maschinenbau GmbH and/or its subsidiaries in the U.S.A. and many other countries. "Teupen", "Access redefined" and "LEO Series" are registered Trademarks of Teupen GmbH in the United States of America and many other countries. Version 2013-A © 2013 Teupen Maschinenbau GmbH.

# Features

## TRACK CHASSIS

- Powerful track drive with hydraulic braking system
- Precise maneuvering over sensitive electrohydraulic cable remote control
- Rubber tracks with specially arranged profile providing optimum grip
- White, non-marking rubber tracks
- Hydraulically height- and width adjustable track chassis

## STABILISATION

- Fully-hydraulic, automatic leveling system with constant outrigger setup monitoring
- Variable stabiliser/outrigger system with one-side or both-sides narrow setup option

## BOOM SYSTEM

- Telescoping boom made from robust steel and aluminium profiles on wear-resistant rollers
- All functions are available from one radio remote control panel
- Electric-proportional controls with intuitive operator guidance
- Robust, lockable control panel with integrated operation & display function
- Self-levelling platform with fully-hydraulic levelling system
- 180° basket rotation
- Boom rotation via high-performance slew ring, worm gear and hydraulic motor
- Basket changing system
- 180° movable jib, even in load limit range
- Coming Home Function - automatic return of boom into transport position

## POWER SOURCES

- 230 V Electric Motor (EU), 115 V Electric Motor (US)
- Kubota Diesel engine D902, silenced
- Start-Stop switch of combustion engine in the basket

## PRODUCTIVITY, SAFETY, QUALITY

- 230 V (EU), 115 V (US) power outlet in the basket
- Ergonomically shaped basket with eyelets for safety belts and tool tray
- Lockable storage box for radio remote control
- High-quality paint in RAL 3020 (red)
- Hydraulic emergency lowering via hand pump
- Cables and hoses are safely routed through the boom structure
- Biodegradable hydraulic oil
- Lock valves - hydraulic return valves directly on all hydraulic cylinders
- Relief valves protecting the hydraulic system from too high pressures
- Protective covers for oil-tank, emergency controls and connecting cables and hoses
- Easily removable covers for optimal accessibility
- Hour meter
- Fuzzy IV controls with interactive display



## OPTIONS

- Snap hooks on boom
- Electric emergency lowering, 12 kg/24 lbs additional weight
- 4 covers on piston rod cylinders (outrigger cylinder), 10 kg/11 lbs additional weight
- Custom paintwork, one colour, according to RAL scheme (except metallic coatings, signal- or special colors)
- Custom paintwork, two colours, according to RAL scheme (except metallic coatings, signal- or special colors)
- Treecare package, consisting of:
  - Protective cover hydraulic tank
  - Protective cover ground control panel
  - Protective cover outrigger cylinders
- 80 V battery drive with charger (in lieu of Kubota Diesel, extra weight approx 400 kg/882 lbs)
- Additional electric drive 230 V/50 Hz (115 V US) for an optimal adjustment of the electric pump to various operation modes
- Height shut-off system for boom, 2 set-points
- Separating grate in basket, 10 kg additional weight
- Basket\* 900 x 800 mm (2ft 11in x 2ft 7in)
- Basket holder, detachable, for 900 x 800 mm basket

*\*Choosing other basket sizes results in different machine specifications and performance and requires additional basket support mount.*

## ACCESSORIES

- 4 Outrigger pads (340 x 850 mm/1ft 1in x 2ft 9in)
- Track mats (2000 x 1000 x 15 mm/6ft 6in x 3ft 3in x ½in), extra durable rubber
- Safety harness
- 2x Protective track covers, made of high-quality polypropylene fabric
- Subframe for truck Mitsubishi Canter, Total weight 450 kg

### Enquiries from Europe, Asia, Middle East & Africa:

#### Corporate Headquarters

**Teupen Maschinenbau GmbH**  
Marie-Curie-Str. 13  
Germany

phone +49 2562 8161-0  
fax +49 2562 6161-888

mail@teupen.com  
www.teupen.com

### Enquiries from North & South America:

#### US Office

**Teupen USA, Inc.**  
10701 Southern Loop Blvd.  
Pineville, NC 28134, USA

phone (704) 248-9871  
fax (704) 248-9889

infousa@teupen.com  
www.teupen.com/us